

UNIGRIPPER



USER MANUAL

UniGripper Control Box with Unigripper Co/Light

REV A

1. Functional Description

UniGripper Co/Light is a lightweight end-of-arm vacuum tool with integrated vacuum generators. The vacuum generators create vacuum using compressed air and the venturi principle. The suction surface of UniGripper Co/Light is equipped with a foam pad that contains an array of suction holes. The suction holes are linked to corresponding UniGripper valves, which automatically sense which suction holes are covered during a lift and focus the vacuum flow to these areas. For more information on the vacuum operation of UniGripper Co/Light, see chapter on Vacuum Principles.

The UniGripper control box includes a pneumatic valve to control whether compressed air is supplied to the UniGripper Co/Light and if the compressed air goes to the vacuum generators, for vacuum creation, or if it is directed into the gripper for fast release of vacuum.

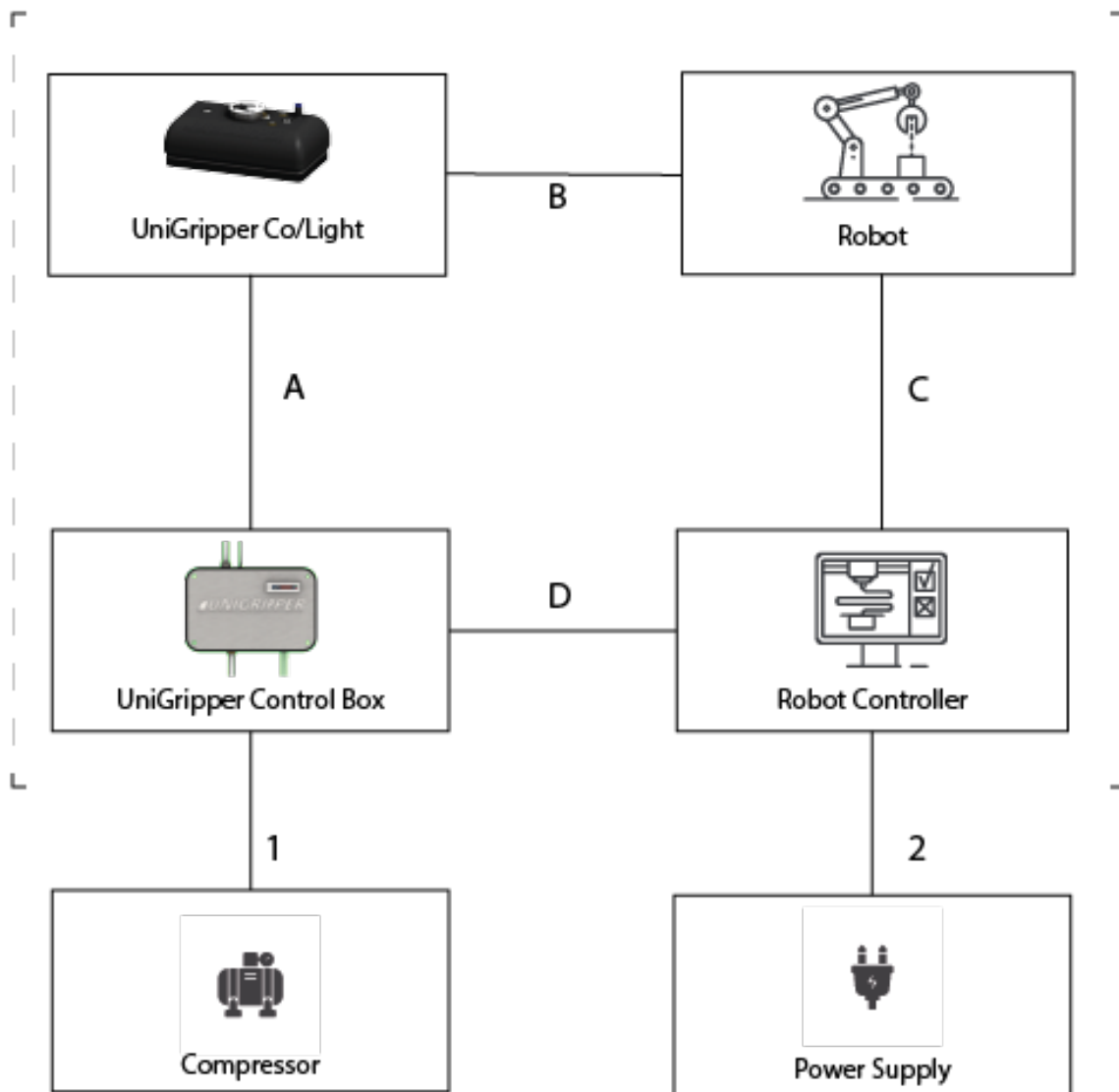

Figure 1 Entities and interfaces of UniGripper Co/Light and UniGripper Control Box

1.1. Interfaces

In Figure 1, 6 interfaces are identified, two external interfaces (labelled 1-2) and four internal interfaces (labelled A-D).

The external interfaces are:

1. Compressed air supply to the UniGripper Control Box.
The compressed air shall be clean and dry and preferably supplied at pressure 6-7bar.
The UniGripper Co/Light can consume 105-420NI/min compressed air, depending on model and configuration.
2. Electrical Power Supply
Only standard supply to the robot controller is required.

The internal interfaces are:

- A. Interface between UniGripper Control Box and UniGripper Co/Light
This is the interface for compressed air. Recommended is to route two tubes for compressed air along the robot arm. One 8mm¹ diameter tube for supply of compressed air to the vacuum generators and one tube 4-6mm diameter for fast releases as well as vacuum sensing.
- B. This is the mechanical interface between the UniGripper Co/Light and the robot.
UniGripper Co/light is delivered with an easy-mounting robot adapter. For more information, see separate chapter on the UniGripper Robot Adapter
- C. Control interface between robot controller and the robot
The interface for robot control is not impacted by installation of the UniGripper Co/light.
- D. Interface between UniGripper Control Box and robot controller
This is an electrical interface and programmatical interface.
The UniGripper control box is delivered with three cables, to be connected to the electrical interface of the robot controller:
 - There are two pieces 2-wire cables, labelled Vacuum ON and Vacuum RELEASE, which are used to control the pneumatic valve in the control box. These two cables are to be connected to digital outputs in the robot controller. In the future of the document, it is assumed that the Vacuum ON cable is connected to DO0 and Vacuum RELEASE is connected to DO1. The colouring of the wires in each cable is not important in terms of which wire is at DOx and which is at 24V
 - There is one 5-wire cable, labelled Vacuum SWITCH, which can give indications of current vacuum level in the UniGripper Co/Light.More information on use of the signals can be found in the chapter about the UniGripper Control Box. In the end of the document is a drawing of an example wiring between the UniGripper Control Box and the robot controller.

¹ 8mm diameter is acceptable if the UniGripper control box is installed close to the robot arm. For tube lengths over 1.5m it is recommended to use thicker tubes

2. UniGripper Robot Adapter

The UniGripper robot adapter consists of two pieces. A brass knob helps keeping the parts in position when mounted together. At assembly, remove the top part of the robot adapter from the gripper by pressing down the brass knob (A) and slide the top part of the adaptor out (B) according to Figure 2. Then mount the top part of the adapter to the robot before sliding the UniGripper Co/Light into the robot adapter top part again.



Figure 2 Disassembly of UniGripper Robot Adapter

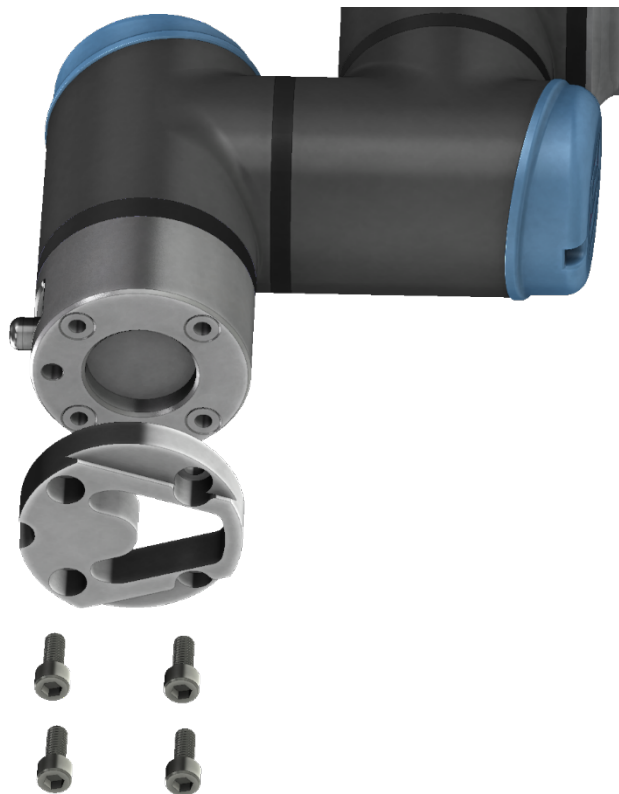

Figure 3 Mounting of UniGripper Robot Adapter top part to Robot

3. Vacuum Principles

The foam pad of the UniGripper Co/Light consists of an array of suction holes. When lifting an object, the lifting force generated by the UniGripper Co/Light on the object is linearly related to the number of suction holes that are completely covered by the object, as well as linearly related to the vacuum level in the suction hole. For air-tight objects, the vacuum in the suction hole is the same as in the rest of the gripper. The UniGripper valves in the UniGripper Co/light also senses where the object is located and focuses the vacuum flow to where the object is. This allows vacuum in the suction hole to be same as in the gripper also for objects that are not air tight. Table 1 indicates lifting force generated by each suction hole at different vacuum levels.

Table 1 Lifting force generated by UniGripper Co/Light Regular at different vacuum levels

Vacuum Level	Lifting force	
	For one suction hole (grams)	For entire gripper (kg)
200mBar	76	9.7
400mBar	152	19.4
600mBar	228	29.1

In Figure 4, two square identical objects are indicated as an overlay on the hole pattern of the UniGripper Co/Light. In the upper instance, the object covers 16 holes and at a vacuum level of 200mBar, the gripper generates a lifting force of app. 1.2kg on the object. In the lower instance, only 9 holes are completely covered and lifting force at same vacuum level gets 684g, which is also the worst case for the object.

The vacuum level achieved in the example above will depend on how many objects are placed on the UniGripper Co/Light’s surface (the more objects, the more of the gripper is covered and the more the gripper is covered, the higher the vacuum level). It will also depend on pressure and amount of compressed air supplied to the UniGripper Co/Light.

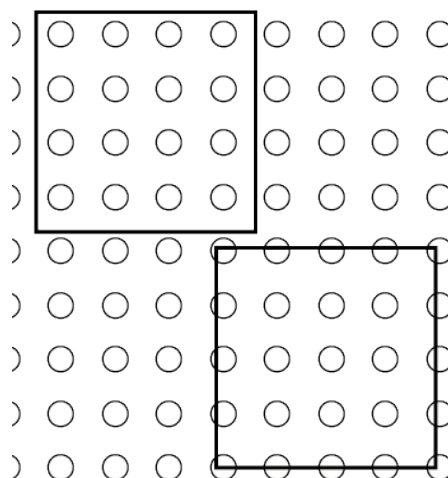

Figure 4 Depiction of different degree of coverage for identical objects.

4. UniGripper Control Box

The UniGripper Control Box contains a 5/3 pneumatic valve with closed mid-position as well as a vacuum switch to get feedback if the vacuum level in the UniGripper Co/light is above or below a threshold. The vacuum switch has two outputs to be able to report two different threshold levels.

Table 2 indicates which states different combinations of digital outputs DO0 and DO1 result in.

Table 2 Meaning of different settings of digital outputs DO0 and DO1

		DO0 (Vacuum ON)	
		0	1
DO1 (Vacuum RELEASE)	0	Valve closed (No air consumption)	Air to vacuum generators
	1	Compressed air through gripper	<Undefined>

Figure 5 shows how digital outputs DO0 and DO1 should be set during a pick-and-place cycle, and how inputs will vary during the same cycle. The vacuum switch is assumed to be configured in a way that one output from the vacuum switch, which is connected to digital input DI0, becomes 1 when vacuum is below a certain threshold and that the other output, which is connected to digital input DI1, becomes 1 when vacuum level is 0.

The level to use for the output connected to digital input DI0, is application dependent. The UniGripper Co/light will reach a specific vacuum level when applying vacuum while not covering any part of the gripper, this is referred to as the basic vacuum level. The basic vacuum level will depend on amount of compressed air supplied to the system and thus needs to be verified during installation. If lifting only one or a few small objects, only a small part of the gripper's surface is covered, and the difference in vacuum level between the basic vacuum level and vacuum level when successfully gripping the objects is small. In such cases it may not be possible to use the vacuum level as an indication of a successful grip. If, on the other hand, a larger part of the gripper's surface is covered, there will be a clear difference between the basic vacuum level and the level when successfully gripping the products.

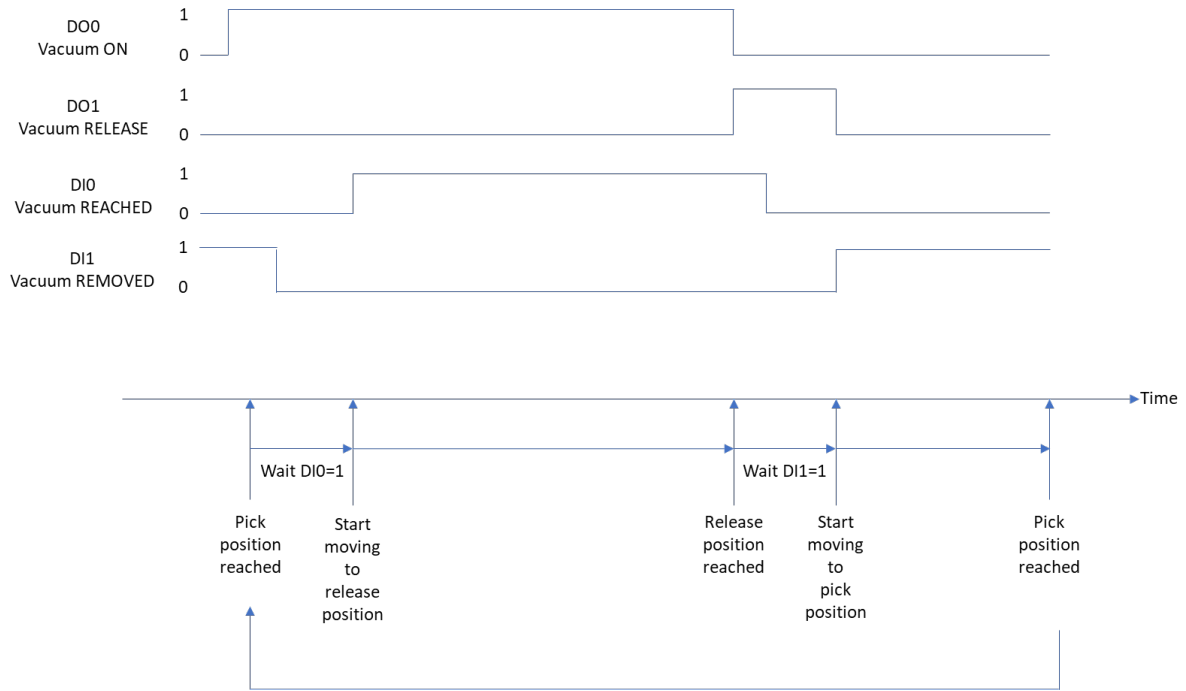

Figure 5 Changes in output and input signals from UniGripper Control Box during a pick and place cycle

4.1. Configuration of Vacuum Switch

The following steps describe how to configure the vacuum switch in the UniGripper Control Box. More settings are available, please refer to the manual of the vacuum switch manufacturer. In part 5, the output is configured to be set when basic vacuum level is reached. This could instead be changed to the vacuum level reached when covering with gripper with product, if the product covers a larger part of the gripper.

1. Change output 1 to reverse setting (makes DIO get high when vacuum is reached)
 - Press S button for 1 second, display shows F0.
 - Click Up button to change display to F1
 - Click S button 2 times, display shows 1_P
 - Click Down button, display changes to 1_n
 - Click S button to confirm setting
 - Press S button 1 second button to go back to default screen
2. Change hysteresis of output 1 to .002
 - Press S button for 1 second, display shows F0.
 - Click Up button to change display to F1
 - Click S button 4 times, display shows H_1 and .500 interchangeably
 - Press Down button until display shown .002 (use up/down buttons for tuning)
 - Click S button to confirm
 - Press S button for 1 second to go back to default screen
3. Change hysteresis of output 2 to .002
 - Press S button for 1 second, display shows F0.
 - Click Up button 2 times to change display to F2
 - Click S button 4 times, display shows H_2 and .500 interchangeably
 - Press Down button until display shown .002 (use up/down buttons for tuning)
 - Click S button to confirm
 - Press S button for 1 second to go back to default screen
4. Set Pressure setting four output 2 to -0.002
 - Click S button 2 times, display shows P_2 and .500 interchangeably
 - Use Down button to change value to -.002
 - Click S button to confirm and go back to default screen
5. Set Pressure setting for output 1
 - Apply vacuum to gripper with gripper uncovered and note the vacuum level this is the <basic vacuum level>
 - Click S, displays shows n_1 and .500 interchangeably
 - Use down button to change value to <basic vacuum level>+.002, i.e. if <basic vacuum level is -.030 then change setting to -.028
 - Click S button to confirm and go back to default screen

5. Wiring Example Between UniGripper Control Box and a Robot Controller

